

Series 2000 Workcentre (New model) - WCA201

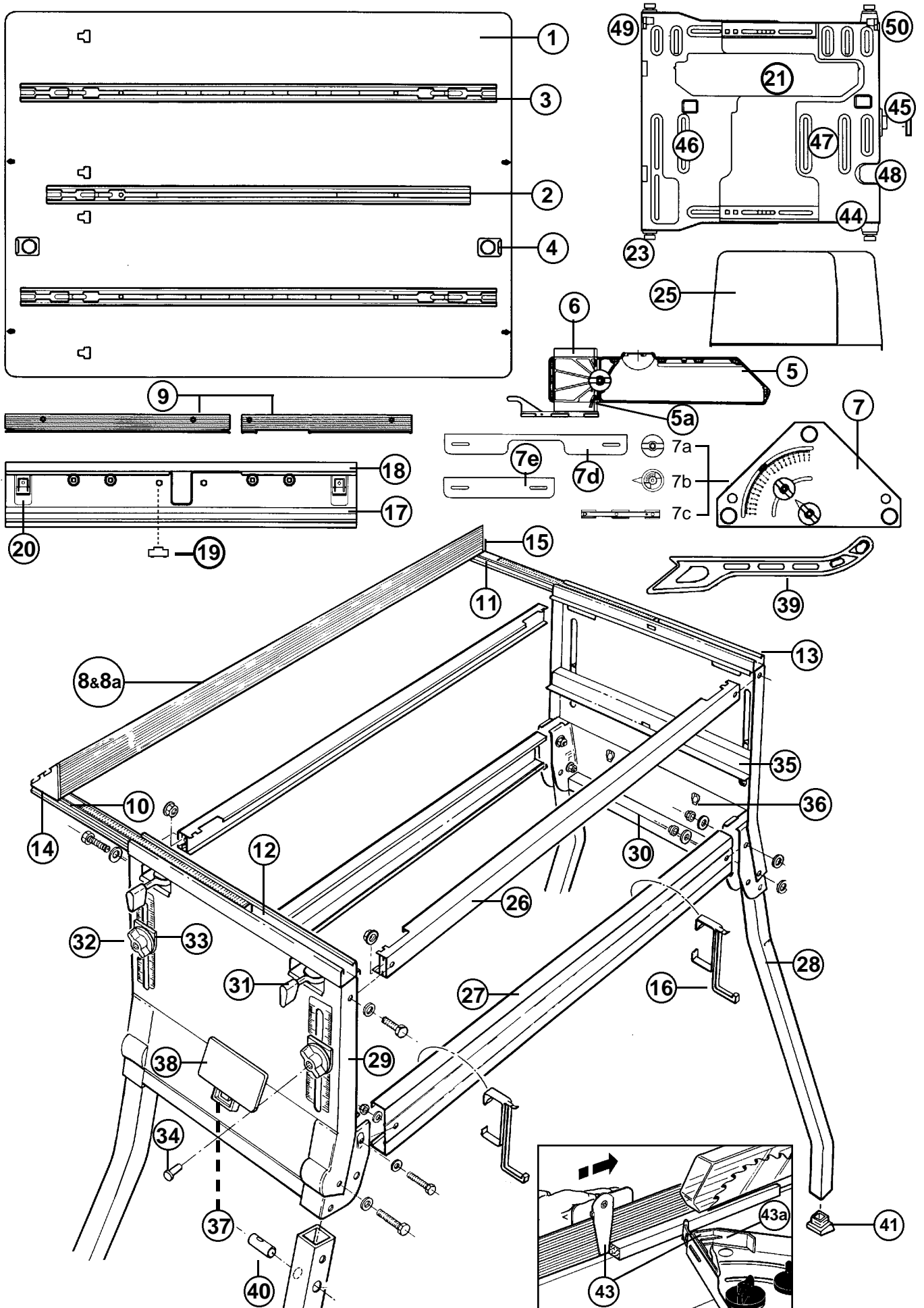

Series 2000 Workcentre (New model) - WCA201

Superseded WCA200 in July 1999

Diag. Ref.	Part No.	Description	Qty Supplied as Spare Part	Comments
-	PUA276	Packing Carton No. 1	1	
-	PUA281	Packing Carton No. 2	1	
-	PUA285	Assembly & Operating Manual	1	
-	VTA031	Assembly Video	1	
1	WCA 235	Table Top (complete)	1	Includes infill strips
2	WCA330	Saw Slot Repair Kit (centre infill strip)	1	
3	WCA446	Protractor Slot Repair Kit (outer)	1	
4	WCA332	Table Latch (complete)	1	
5	WCA333	Overhead Guard	1	Includes 6mm bolt & knob
5a	WCA192	Overhead Guard Hold-down Fingers	2	
6	WCA334	Guard Support	1	
7	WCA251	Protractor (complete)	1	
7a	WCA335	Protractor Knob	1	Includes M6 nut
7b	WCA223	Protractor Lock Pointer	1	
7c	WCA222	Protractor Slide Strip	1	
7d	WCA220	Protractor Sandpaper (long)	1	
7e	WCA221	Protractor Sandpaper (short)	1	
8	WCA336	Rip Fence (no bevel guides)	1	Includes inner tracks (10 & 11)
8a	WCA210	Rip Fence (no fittings)	1	Extrusion only
9	WCA337	Rip Fence Bevel Guide Set	1	Set of 2
10	WCA259	Fence Track Inner - Front	1	
11	WCA260	Fence Track Inner - Rear	1	
12	WCA313	Fence Track Outer - Front	1	
13	WCA283	Fence Track Outer - Rear	1	
14	WCA217	Fence Cap - front	1	
15	WCA218	Fence Cap - rear	1	
16	WCA293	Fence Hanger	1	
17	WCA338	Cross-Cut Fence (complete)	1	Also suits MK2 & MK3 Workcentres
18	WCA299	MDF Sub-fence (50 x 16mm)	1	
19	WCA339	Nylon Feet for crosscut fence	4	Includes nuts & bolts
20	WCA378	Fence Catches	2	
21	WCA400	Saw Slide Chassis	1	
46	WCA403	Chassis - front	1	Available separately
47	WCA406	Chassis - rear	1	Available separately
23	WCA447	Bearings	4	Includes bolts & nyloc nuts
24	CMA024	Saw Clamp Tree	1	
25	WCA388	Saw Side Guard (2 piece)	1	Includes bolts & nyloc nuts
26	WCA247	Bearing Channel	1	
27	WCA256	Base Channel	1	
28	WCA204	Leg	1	
29	WCA274	End Panel Assembly - front	1	Includes switchbox
30	WCA279	End Panel Assembly - rear	1	
31	WCA342	Cam Lock Assembly	1	
32	WCA343	Table Support Bag / Kit	1	Includes knob, bolt & indicator
33	WCA285	Nylon Scale Indicator	4	
34	WCA281	Push Stick Hanger	2	
35	WCA254	Table Support Rail	1	Front & rear identical
36	WCA267	Protractor Hooks	2	
37	CMA050	Switchbox (complete)	1	
38	CMA048	Stop Plate	1	
	CMA062	Stop Plate pin	1	
43	WCA369	Captive Pusher & Side Pressure Finger Kit	1	
39	CMA036	Push-Stick - conventional type	1	
43a	WCA374	Side Pressure Finger Kit (for protractor)	1	2 replacement fingers & holder

Specifications:

Carton 1 - Packed weight: 27kg

Pack Size: 893 x 655 x 110mm **Volume:** 0.073m³

Carton 2 - Packed weight: 8.65kg

Pack Size: 990 x 210 x 75mm **Volume:** 0.016m³

Paint: Epoxy powder coat (oven cured)

Main Body: Telecom Gold

Legs: Charcoal Grey

Table Infills: Aluminium Powder Coated Silver **Legs:** 30mm Square Tube **Overhead Guard:** Clear Polycarbonate

Bearing Channels & Rip Fence: Aluminium

Bearings: Nylon 66

Sheet Metal Parts: 1.60mm Mild Steel

Series 2000 Workcentre (New model) - WCA201

Superseded WCA200 in July 1999

Diag. Ref.	Part No.	Description	Qty as packed in Fastener Bags	Comments
------------	----------	-------------	--------------------------------	----------

FASTENERS NOT SUPPLIED SEPARATELY - EXCEPT THOSE NOTED BELOW

40	WCA245	Leg Lock Pin (complete)	4	
41	CMA042	Angled foot	4	
m	WCA311	Router Table Fitting Kit	1	Not supplied as standard
42	WCA284	Main Fastener Bag	1	Includes saw clamp set
42a	-	M8 x 16 Bolt	4	} Available in WCA282
42b	-	M8 Flange Nut	4	
42c	-	8mm Washer	20	
42d	-	M8 Nyloc Nut	8	
42e	-	M8 x 50 Bolt	8	
42f	WCA281	Push stick hanger	2	Available separately
42g	-	$\frac{3}{16}$ " Nut	3	
42h	-	$\frac{3}{16}$ " Screw	3	
42i	WCA314	Scale Pointer Labels	1pr	} Available separately
42j	CMA042	Angled foot	4	
42k	CMA020	Tube Spanner	1	
42l	AGA001	Trigger Strap	1	} Not supplied as standard
m	WCA311	Router Table Fitting Kit - available free on request	1	
43	WCA417	Triton saw alignment cams	1	} Available separately
44	WCA408	Bearing spacer	1	
45	WCA409	Chassis hook	1	
48	WCA416	Chassis brace	1	
49	WCA411	Saw guard pivot - front	1	
50	WCA412	Saw guard pivot - rear	1	

